



Installation Instructions

2021 FORD F150 RED STEEL REAR

Product Number: RT5150
Application: 2021 FORD F150

RT5150 PREMIUM Rear

ITEMS:

- 22457 – Red Steel Rear Bumper
- 61672 – License Plate Light
- T5050-IM
- 50023-HW
- TXX50-HW
- 61632 – Epoxy QTY 2

FAB FOURS ID	DESCRIPTION	QTY
TXX50-HW	1/2" License Plate Nut	2
TXX50-HW	1 3/8" Rubber Grommet	4
TXX50-HW	Plastic Plug	4

FAB FOURS ID	DESCRIPTION	QTY
50023-HW	7/16"-14 X 1.25" Yellow Zinc Hex Head Bolt, Grade 8	6
50023-HW	7/16"-14 Yellow Zinc Hex Nut, Grade 8	6
50023-HW	7/16" Yellow Zinc Lock Washer, Grade 8	6
50023-HW	7/16" Yellow Zinc Flat Washer, Grade 8	12





Installation Instructions

2021 FORD F150 RED STEEL REAR

Product Number: RT5150
Application: 2021 FORD F150

I. Tools Required

- Socket Wrench with Extensions
- Body Pry Tool
- 5/8", 11/16", 8mm, 9mm, and 13mm Sockets
- 5/8", 11/16", 8mm, 9mm, and 13mm Box End Wrench





Installation Instructions

2021 FORD F150 RED STEEL REAR

Product Number: RT5150
Application: 2021 FORD F150

I. Removal of Stock Bumper

1. Remove license plate and OEM license plate lights from the bumper. Disconnect trailer plug and sensor harness plugs from the sensors, and license plate lights so that the harness is no longer attached to the OEM bumper. Figure 1.

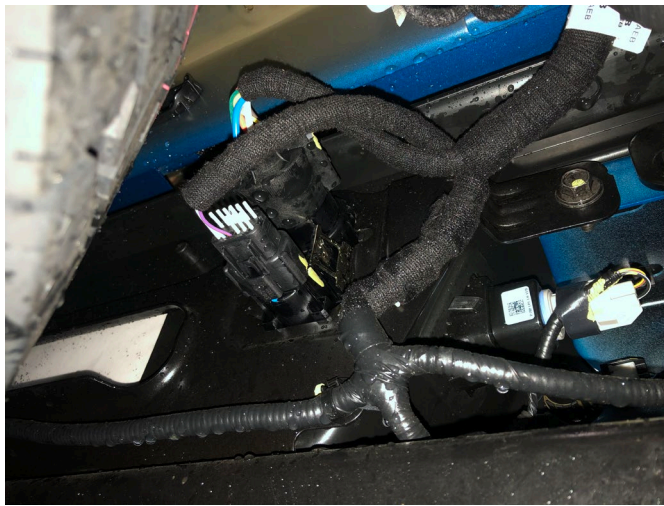

Figure 1.



Installation Instructions

2021 FORD F150 RED STEEL REAR
Product Number: RT5150
Application: 2021 FORD F150

2. Remove one (1) Christmas tree plug and (1) clip connecting the harness to the frame.
4. Remove seven plastic Christmas tree plugs holding the harness to the inside of the bumper. Fish the harness out of the bumper and out of the way.
5. The OE bumper will come off in 3 pieces. From the outside and starting from the passenger side edge peel away the plastic that is clipped into the top of the bumper (Figure 2). Flat head screwdriver is recommended for removal.

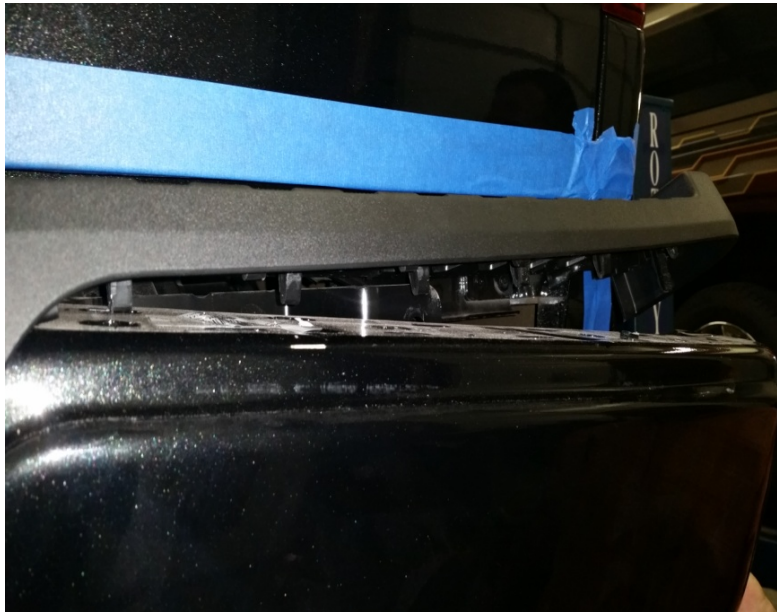

Figure 2



Installation Instructions

2021 FORD F150 RED STEEL REAR
Product Number: RT5150
Application: 2021 FORD F150

6. Remove the final 10 bolts that are now accessible using a 13mm socket. (Figure 3a-c)

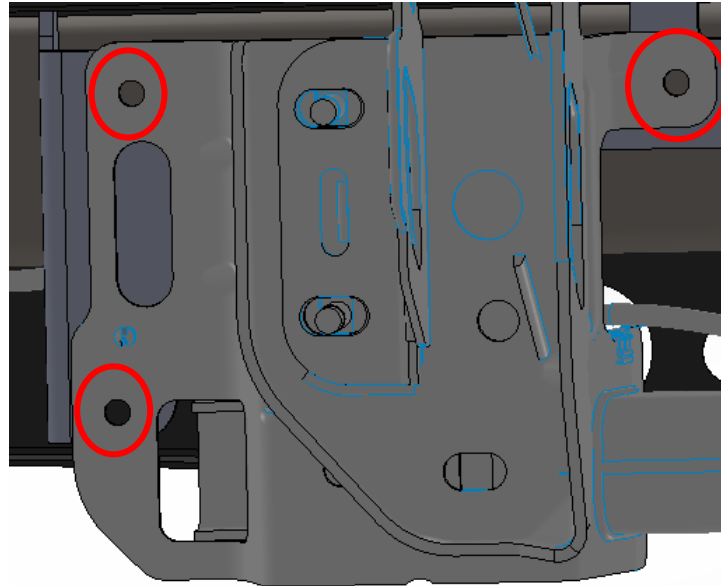

Figure 3a (3x per side, Outer Bolt Locations)



Figure 3b (2x per side, Inner bolt locations)





Installation Instructions

2021 FORD F150 RED STEEL REAR
Product Number: RT5150
Application: 2021 FORD F150

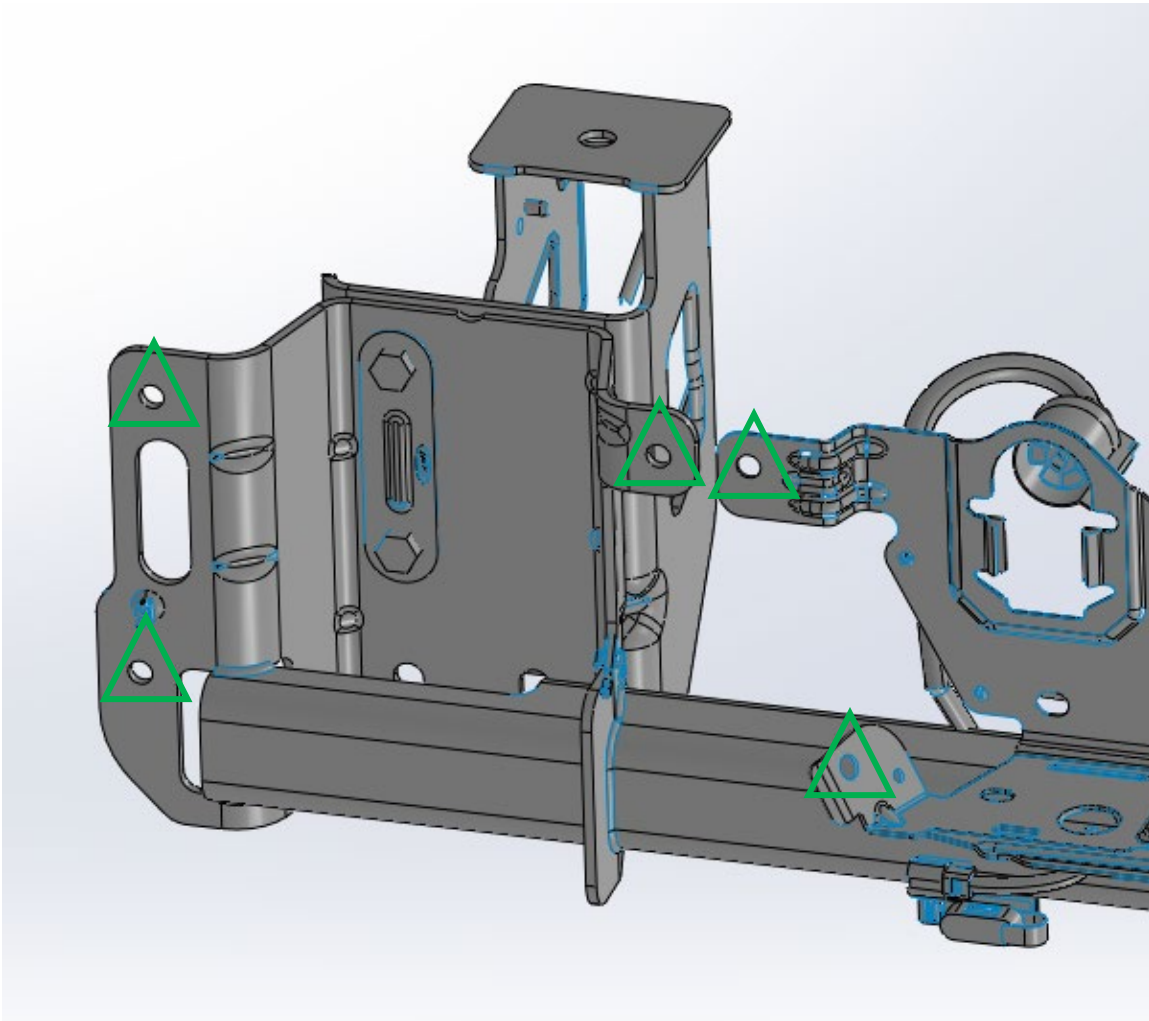

Figure 3c (5x Bolt Locations per Side)





Installation Instructions

2021 FORD F150 RED STEEL REAR

Product Number: RT5150
Application: 2021 FORD F150

7. Install the sensor housings and sensors into the new bumper with the provided rubber grommets.
8. Before installing the bumper: Trim the center plate and lower step mounting points off the frame using a cutoff wheel. Figure 4-5.



Figure 4



Figure 5





Installation Instructions

2021 FORD F150 RED STEEL REAR
Product Number: RT5150
Application: 2021 FORD F150

9. With assistance, hold the bumper in place and use the provided 7/16" bolts, washers and nuts to attach it to the frame.

10. Position the bumper as desired and make sure the tailgate does not interfere with the bumper when opened. Once the bumper is positioned, fully tighten all mounting hardware.

